

# WORKSHOP PRACTISE

An Introduction

For all engineering students of 1<sup>st</sup> year.



ESTD

2018

By ARJUN PRAMANIK  
Assistant Professor,  
Dept. of Mechanical Engg.  
NSU Jamshedpur.

# SCOPE AND OBJECTIVES

- In order to gain a good basic knowledge of **manufacturing process**, a student entering the first year of engineering degree, should undergo a course on workshop practice.
- In order to have a balanced overall development of budding engineers, it is necessary to **integrate theory with practice.**
- General workshop practices are included in the curriculum in order to provide **hands on experience about use of different engineering materials, tools , equipments and processes** that are common in the engineering field.
- Besides above, the development of **dignity of labour, precision, safety at work place, team working and development of right attitude** are the other objectives.

# WHAT IS A MANUFACTURING PROCESS?

It is sequence of operations wherein the input material is converted and transformed into finished products by using human effort or a machine

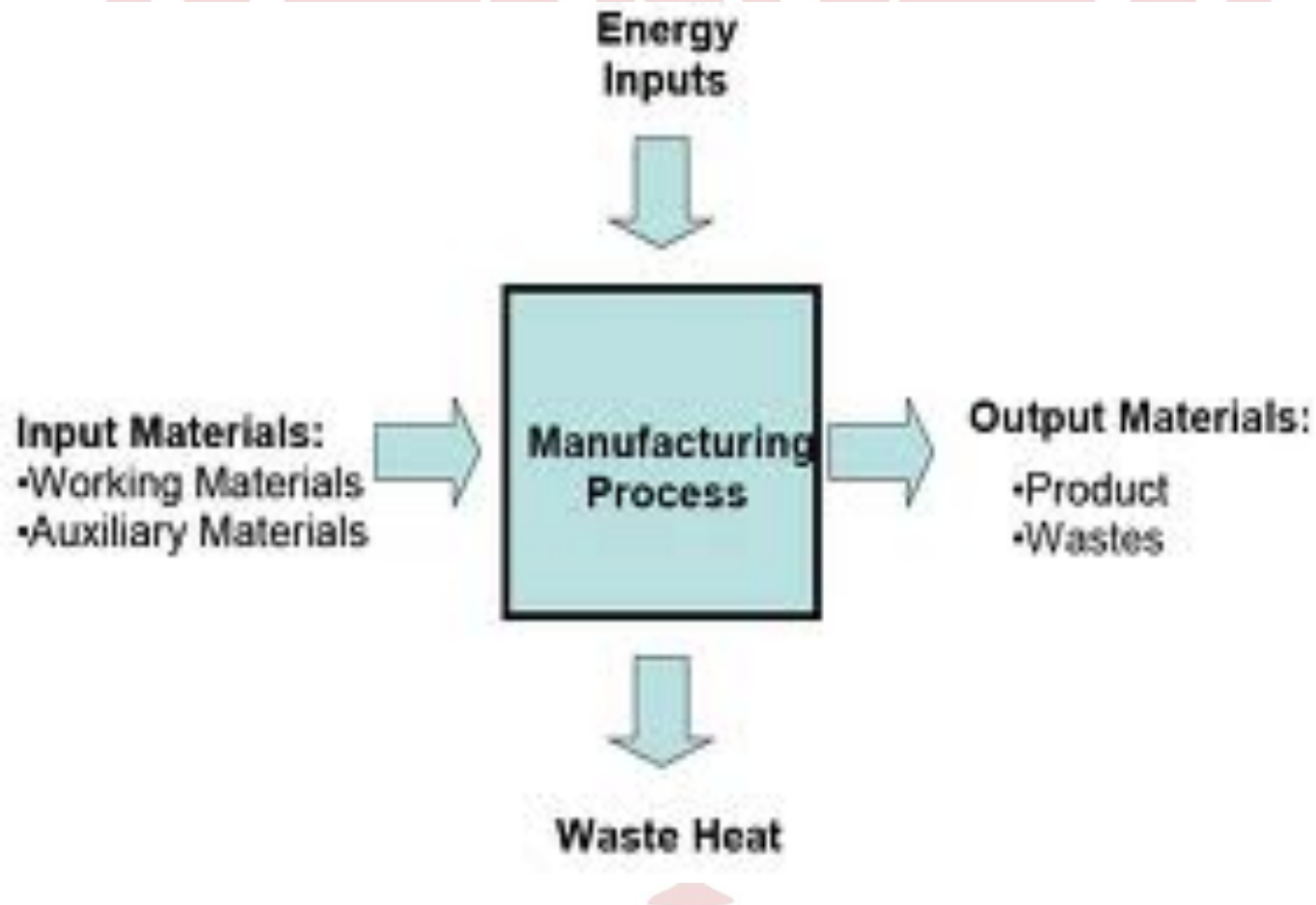

# EXAMPLE OF A MANUFACTURING PROCESS

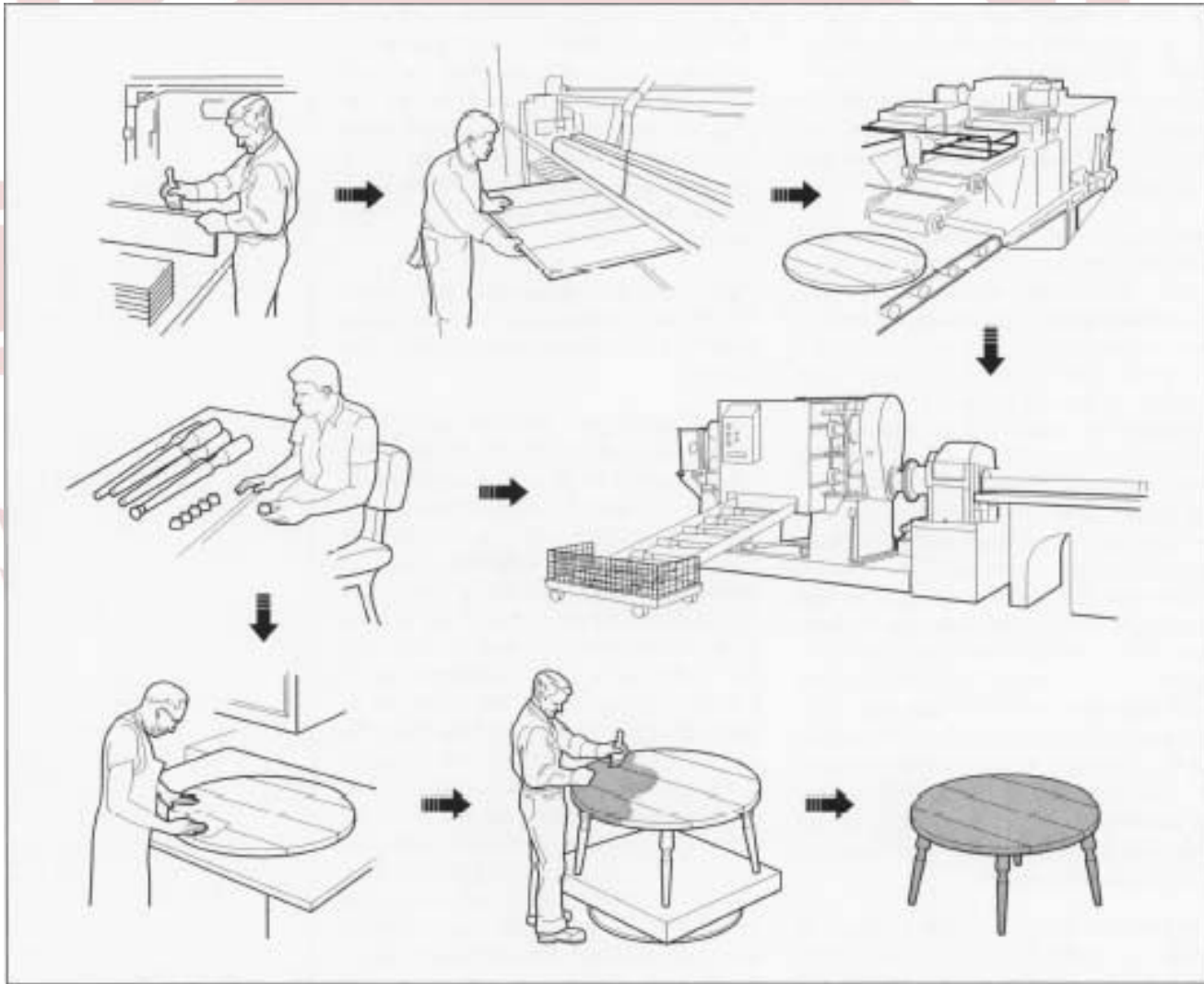

ESTD

018

# WHAT IS WORKSHOP PRACTISE ?

- Workshop practice gives the basic working knowledge required for the production of various engineering products.
- It explains the construction, function, use and application of different working tools, equipment, machines as well as the technique of manufacturing a product from its raw material.

# **TRADES IN WORKSHOP PRACTISE**

- **Carpentry Shop**
- **Fitting Shop**
- **Plumbing Shop**
- **House Wiring**
- **Sheet Metal Shop**
- **Welding Shop**

ESTD

NSU  
JAMSHEDPUR

2018

# CARPENTRY

- Carpentry may be defined as the process of making wooden components.
- It starts from a marketable form of wood and ends with a finished product. It deals with building work, furniture, cabinet making etc.
- Joinery, i.e. preparation of joints is one of the important operations in all wood-works. It deals with specific work of a carpenter like making different types of joints to form a finished product.
- Working with wood for various applications. A student has to study commonly used carpentry joints such as Cross lap joint, Tee joint, Dovetail joint, Mortise & tenon joint etc.

# CURRICULUM FOR CARPENTRY

- Introduction to various types of wood such as Deodar, Kail, Partal, Teak, Mango, Sheesham, etc. (Demonstration and their identification).
- Demonstration, function and use of commonly used hand tools. Care, maintenance of tools and safety measures to be observed.

**Job I Marking, sawing, planning and chiseling & their practice (size should be mentioned).**

- Introduction to various types of wooden joints, their relative advantages and uses.

Job II Preparation of half lap joint

Job III Preparation of Mortise and Tenon Joint

- Safety precautions in carpentry shop



# TOOLS USED IN CARPENTRY

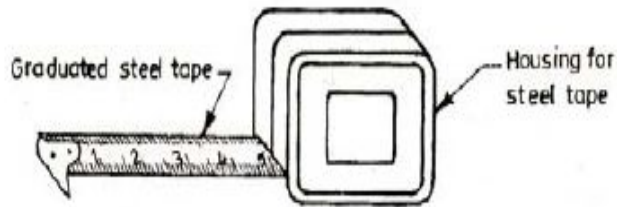
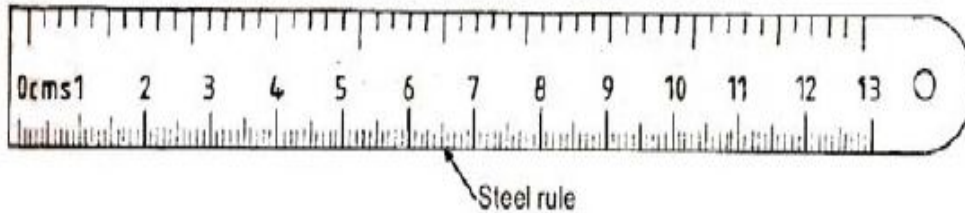

Figure 2.1: Steel rule and Steel tape  
a. Marking gauge

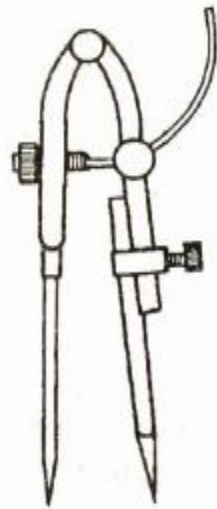

Figure 2.3: Try square

b. Mortise gauge

Figure 2.2: Marking gauges

# TOOLS USED IN CARPENTRY



Compass

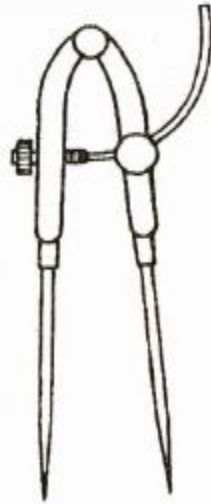

Divider



Scriber or marking knife

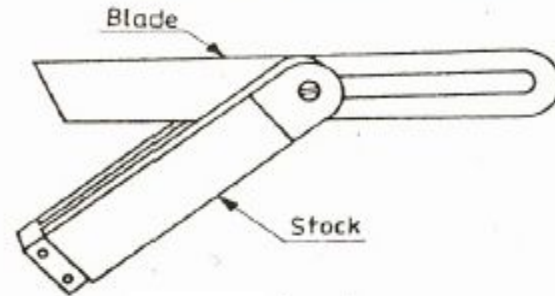

Blade

Stock

Bevel

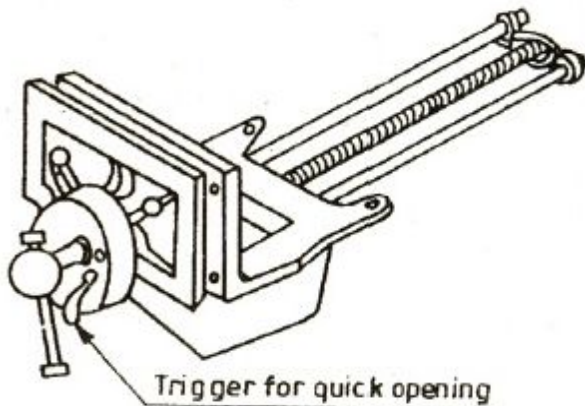

Trigger for quick opening

Figure 2.6: Carpenters vice

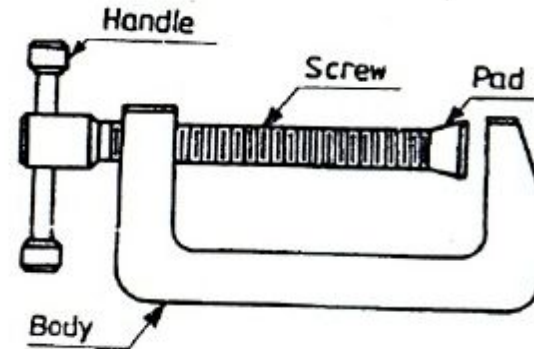

Handle

Screw

Pad

Body

Figure 2.7: C-clamp

# TOOLS USED IN CARPENTRY

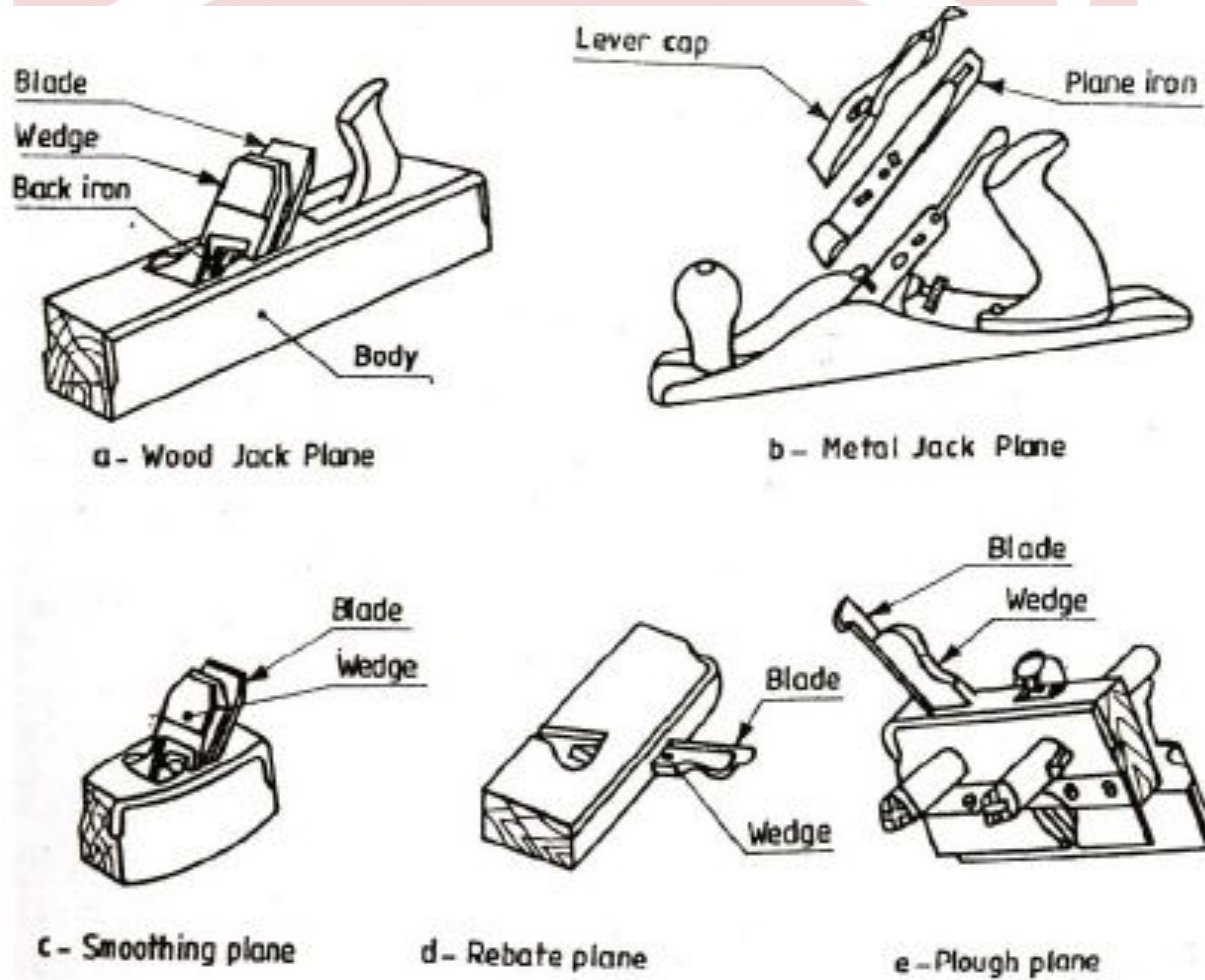

ESTD

18

Figure 2.9: Types of planes

# TOOLS USED IN CARPENTRY

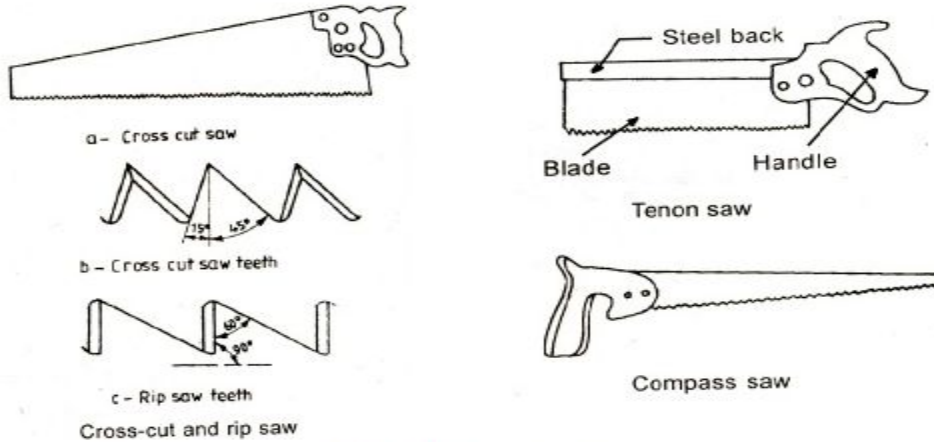

Figure 2.10: Types of saws

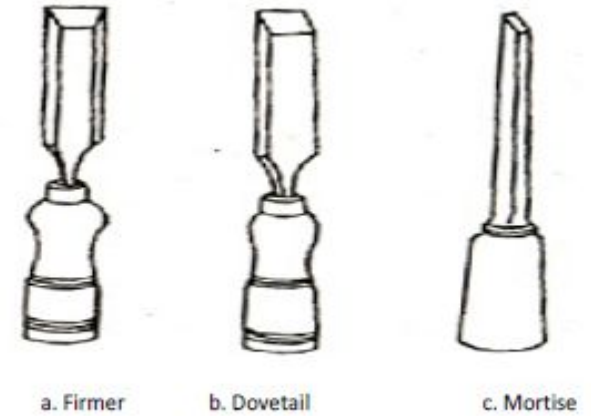

Figure 2.12: Types of chisels

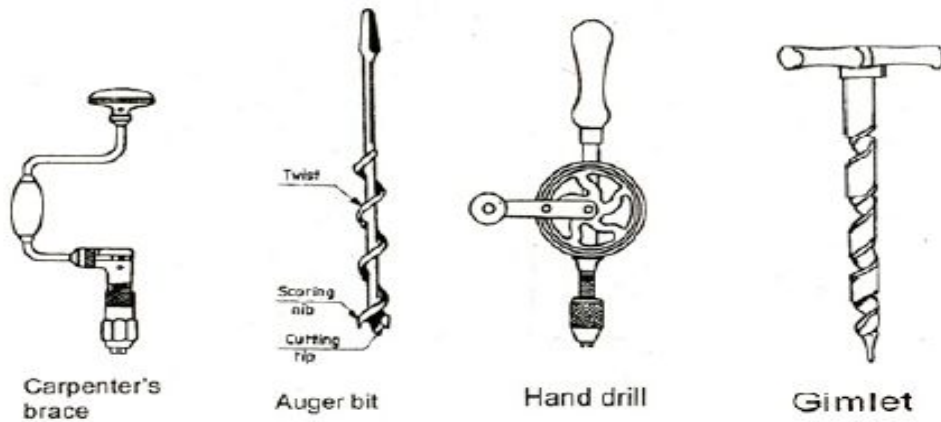

Figure 2.13: Drilling tools

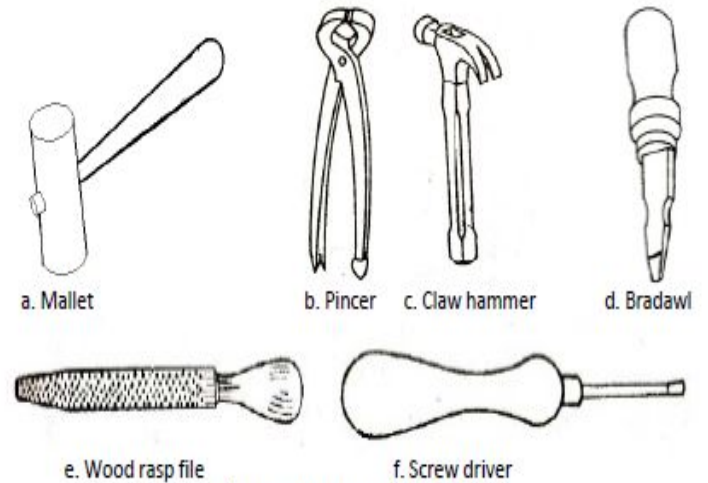

Figure 2.14: Miscellaneous tools

# WOOD JOINTS

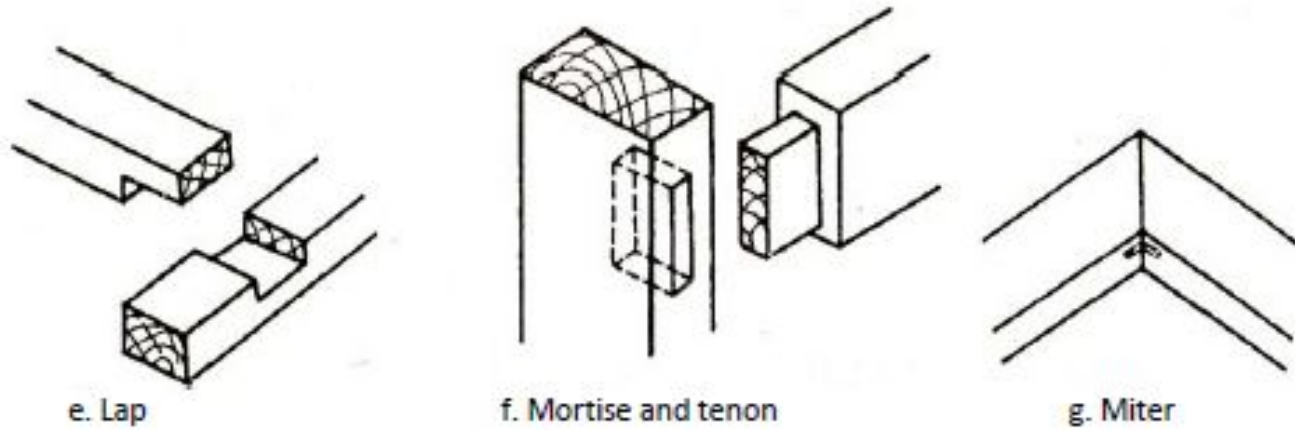
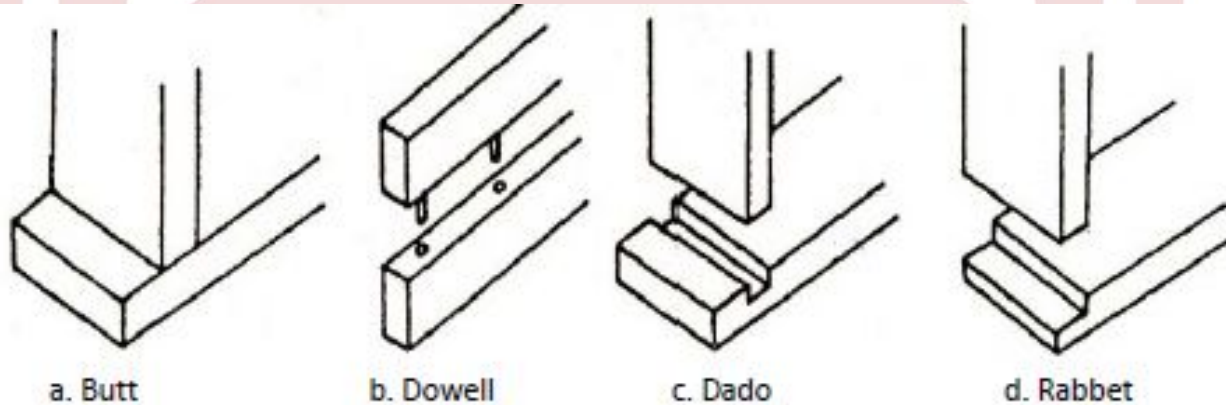

Figure 2.15: Common wood joints

# SAFE PRACTICES IN CARPENTRY SHOP

The following are some of the safe and correct work practices in carpentry shop, with respect to the tools used

1. Tools that are not being used should always be kept at their proper places.
2. Make sure that your hands are not in front of sharp edged tools while you are using them.
3. Use only sharp tools. A dull tool requires excessive pressure, causing the tool to slip.
4. Wooden pieces with nails, should never be allowed to remain on the floor.
5. Be careful when you are using your thumb as a guide in cross-cutting and ripping.
6. Test the sharpness of the cutting edge of chisel on wood or paper, but not on your hand.
7. Never chisel towards any part of the body.
8. Do not use chisels where nails are present. Do not use chisel as a screw driver.
9. Do not use a saw with a loose handle.
10. Always use triangular file for sharpening the teeth.
11. Do not use a saw on metallic substances.
12. Do not use mallet to strike nails.
13. Do not use plane at the places, where a nail is driven in the wood.



# FITTING

- Fitting is a manufacturing process which refers to Assembling of parts together and removing metals to secure necessary fit.
- This operations include measuring & marking, sawing, chipping, filing etc.
- Students have to practice Stepped joint, V-joints, Dovetail joints etc.

# CURRICULUM FOR FITTING

- Introduction to fitting shop tools, common materials used in fitting shop, Identification of materials. Such as Steel, Brass, Copper, Aluminium etc.

Description and demonstration of various types of work benches, holding devices and files. Precautions while filing.

- Description and demonstration of simple operation of hack-sawing, demonstration and description of various types of blades and their specifications, uses and method of fitting the blade.

Job I Marking of job, use of marking tools and measuring instruments.

Job II Filing a dimensioned rectangular or square piece of an accuracy of  $\pm 0.5\text{mm}$

Job III Filing practice (production of flat surfaces). Checking by straight edge.

Job IV Making a cutout from a square piece of MS Flat using hand hacksaw.

- Care and maintenance of measuring tools like calipers, steel rule, try square, vernier calipers, micrometer, height gauge, combination set. Handling of measuring instruments, checking of zero error, finding of least count (all gauges including dial gauge).



# TOOLS USED IN FITTING

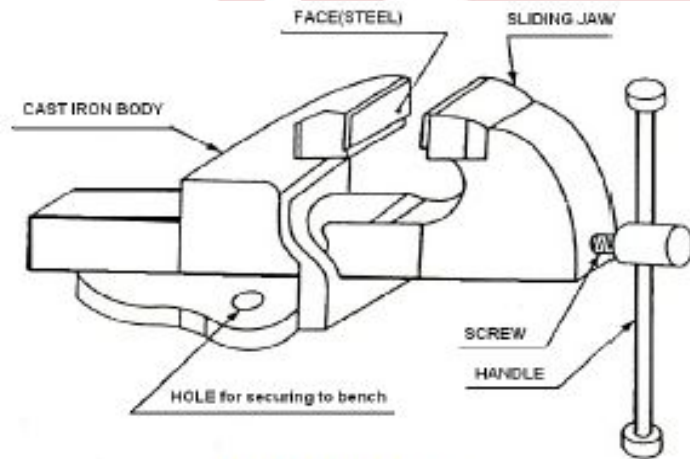

Figure 1.1: Bench Vice

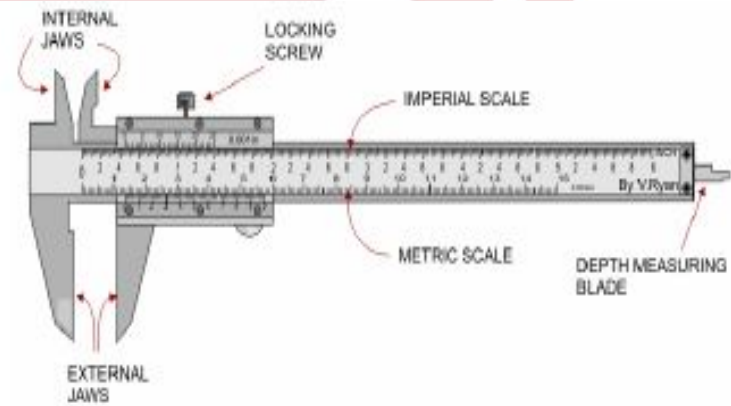

Figure 1.11: Vernier caliper

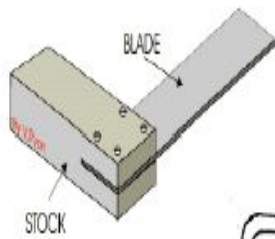

Figure 1.6: Try square

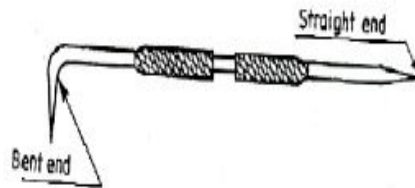

Figure 1.7: Scriber

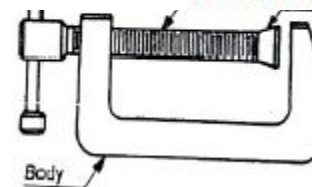

Figure 1.3: C-clamp

# TOOLS USED IN FITTING

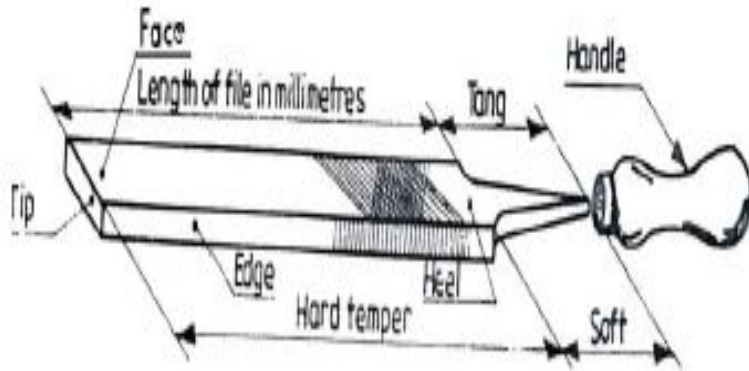

Figure 1.21: Parts of a hand file

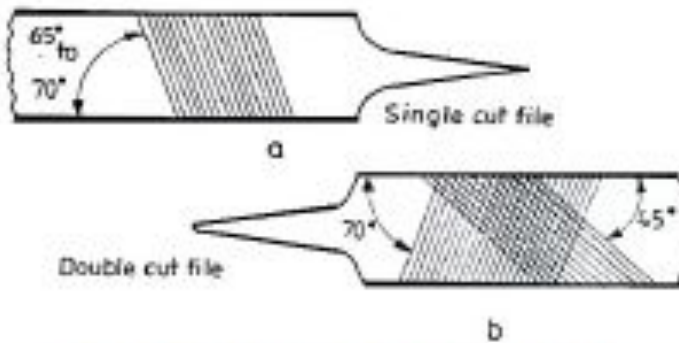

Figure 1.22: Single and double cut files

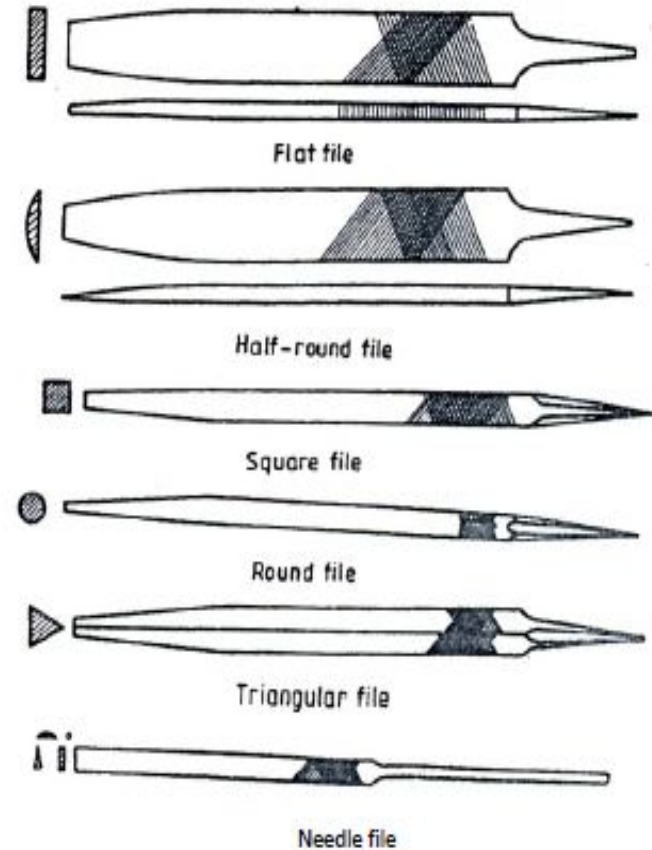

Figure 1.23: Types of files

# TOOLS USED IN FITTING

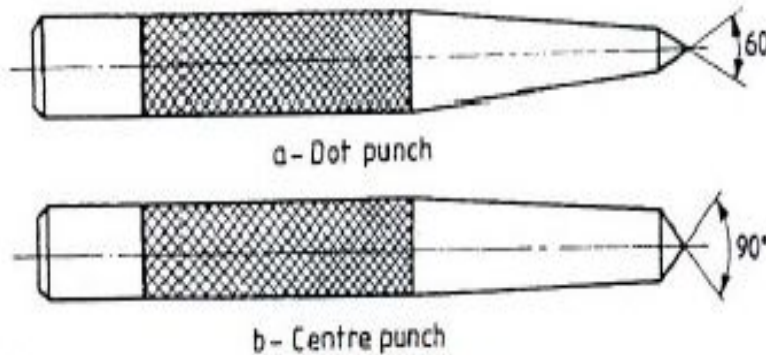

Figure 1.9: Punches

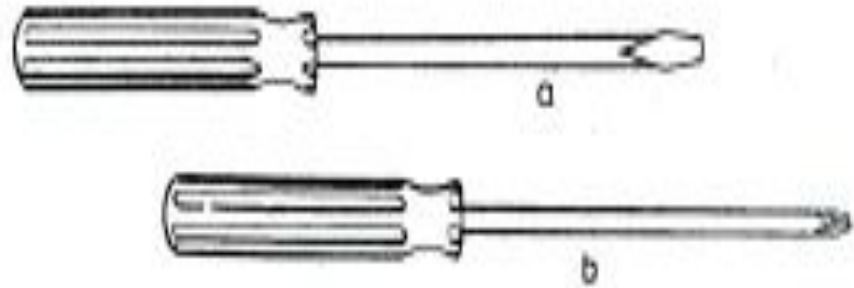

Figure 1.28: Screw drivers

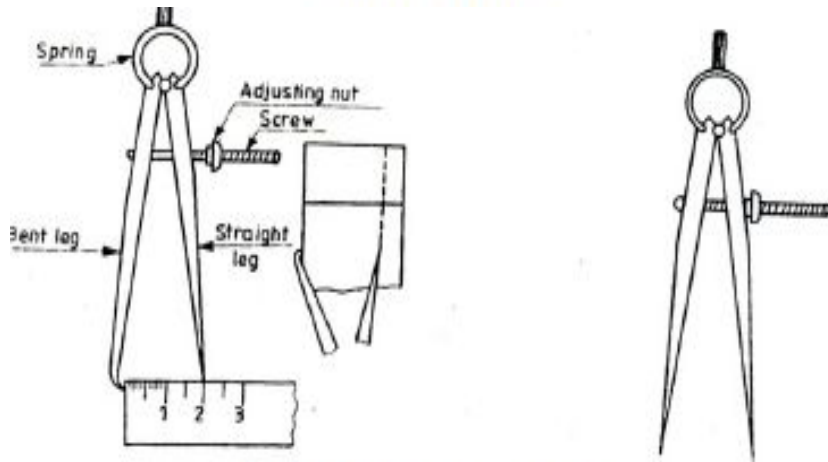

Figure 1.8: Odd leg caliper and divider

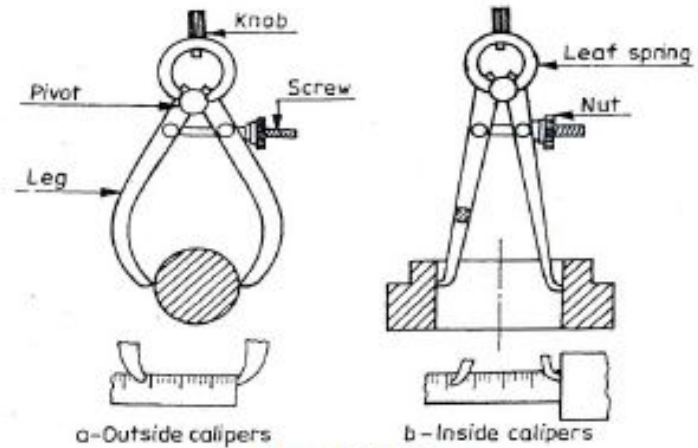

Figure 1.10: Calipers

# TOOLS USED IN FITTING

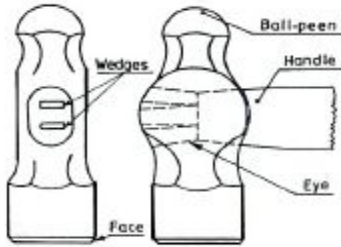

Figure 1.25: Ball peen hammer

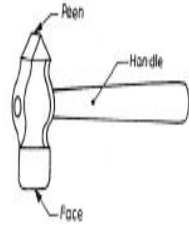

Figure 1.26: Cross peen hammer

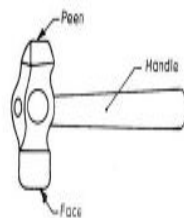

Figure 1.27: Straight peen hammer

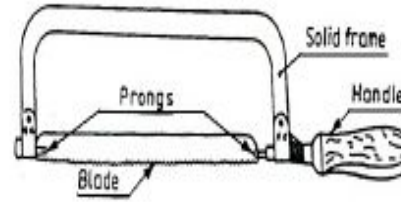

Figure 1.13: Hacksaw frame with blade

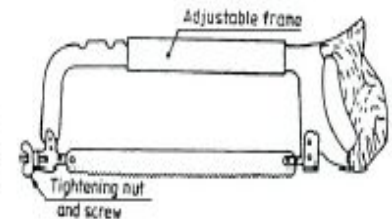

Figure 1.15: Flat chisel

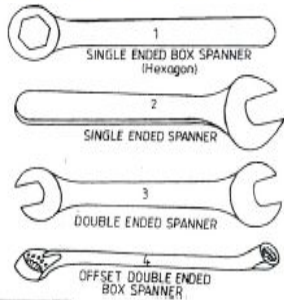

Figure 1.28: Spanners

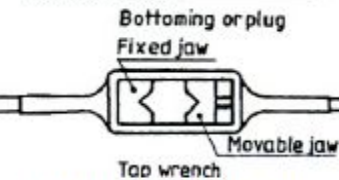
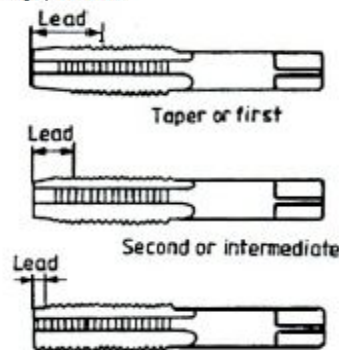

Figure 1.17: Taps and tap wrench

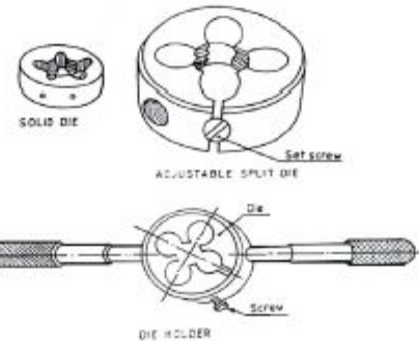

Figure 1.18: Dies and die holder

# TOOLS USED IN FITTING

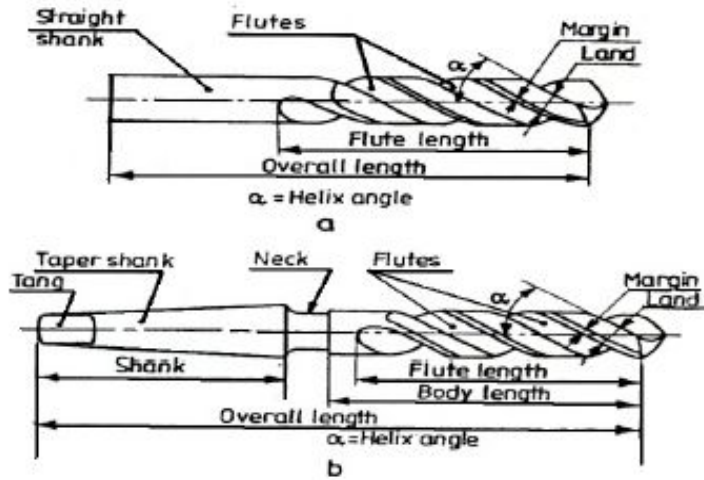

Figure 1.16: Twist drills

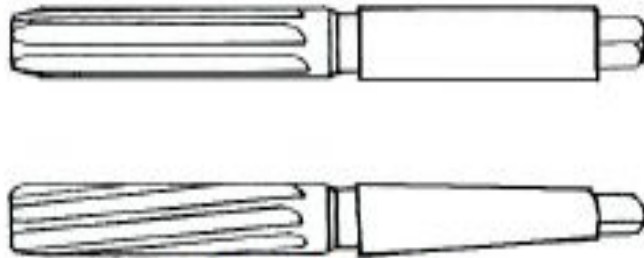

Figure 1.20: Reamers

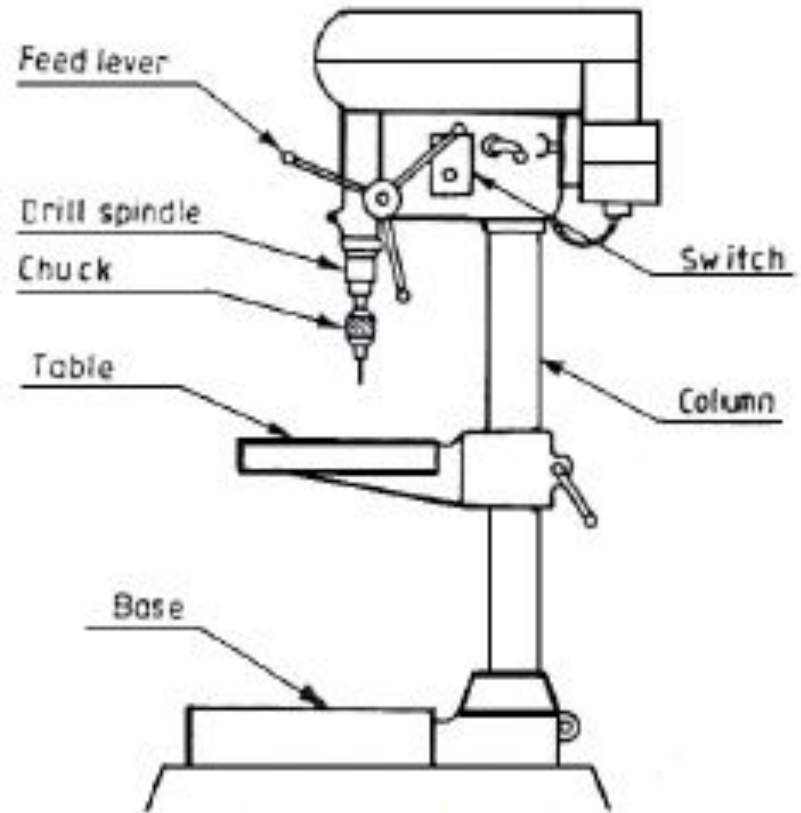

Figure 1.19: Bench drill

# SAFE WORK PRACTICES IN FITTING

The following are some of the safe and correct work practices in bench work and fitting shop, with respect to the tools used

1. Keep hands and tools wiped clean and free of dirt, oil and grease. Dry tools are safer to use than slippery tools.
2. Do not carry sharp tools on pockets.
3. Wear leather shoes and not sandals.
4. Don't wear loose clothes.
5. Do not keep working tools at the edge of the table.
6. Position the work piece such that the cut to be made is close to the vice. This practice prevents springing, saw breakage and personal injury.
7. Apply force only on the forward (cutting) stroke and relieve the force on the return stroke while sawing and filing.
8. Do not hold the work piece in hand while cutting.
9. Use the file with a properly fitted tight handle.
10. After filing, remove the burrs from the edges of the work, to prevent cuts to the fingers.
11. Do not use vice as an anvil.

# PLUMBING

- Plumbing deals with the laying of pipelines. Pipeline provides the means of transporting the fluids.
- It is obvious that laying out the pipeline requires a number of joints to be made and a number of valves incorporated.
- Plumbing work does not require many tools except pipewrenches, hacksaw, pipe-cutter, Threading equipment and pipe-vise.

# **CURRICULUM FOR** **PLUMBING**

- Study of Plumbing tools.
- Demonstration of plumbing work in domestic and industrial applications.
- Study of pipe joints, cutting, threading and laying of pipes with different fittings using PVC pipes.
- Use of special tools in plumbing work.



# CURRICULUM FOR PLUMBING

- Study of Plumbing tools.
- Study of pipe joints and pipe fittings, cutting, threading and laying of pipes with different fittings using PVC pipes.

Job I: To cut the given GI pipe to the required length and to perform threading as per given sketch.

Job II: Pipe cutting, threading and fitting to make a three way junction using Tee Eql, Elbow & Coupling with bibcock.

Job III: Pipe cutting, threading and fitting to make a connection of Gate- valve , bibcock and shower along with elbow Tee EQL.

- Use of special tools in plumbing work.

# TOOLS USED IN PLUMBING

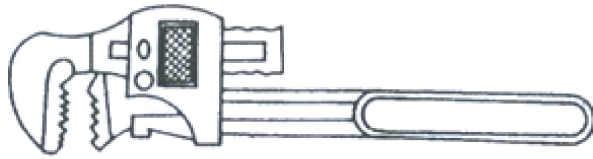

Pipe wrench.

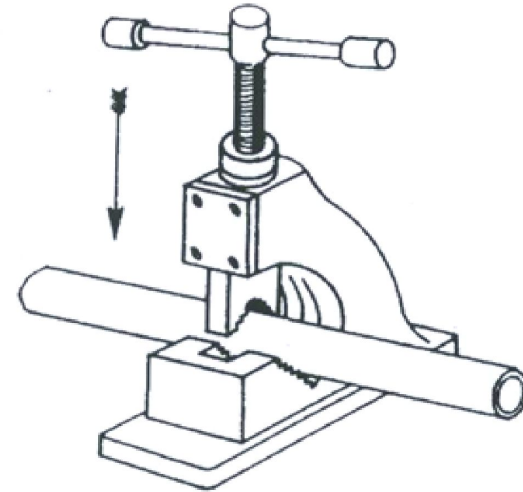

Pipe vice.

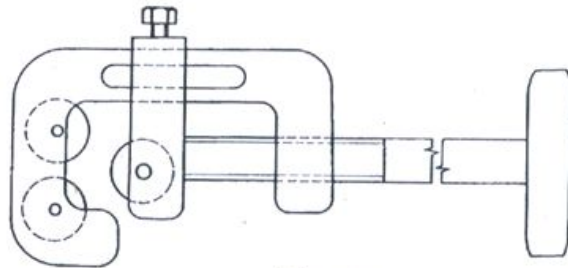

Pipe cutter.

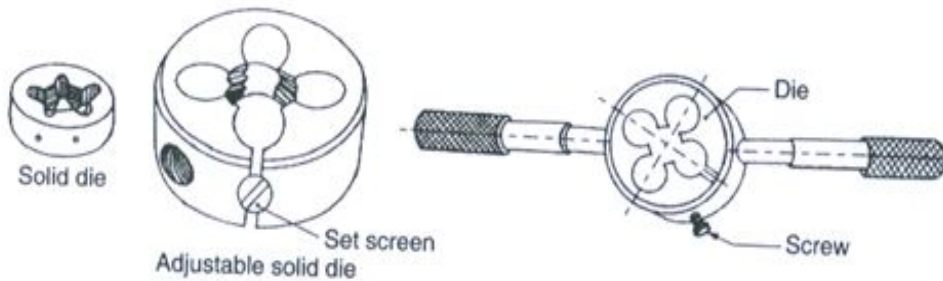

Threading dies and taps.

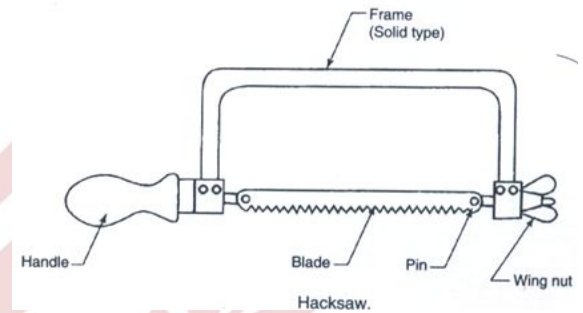

File and rasn

# CURRICULUM FOR HOUSE WIRING

- Study, demonstration and identification of common electrical materials such as wires, cables, switches, fuses, ceiling roses, PVC Conduits, PVC Channels and allied items, tools along with electrical instruments such as voltmeter, ammeter and multimeter
- Study of electrical safety measures and demonstration about use of protective devices such as fuses, MCBs, ELCBs and relays including earthing
- Job I Identification of phase, neutral and earth of domestic appliances and their connection to two pin/three pin plugs.
- Job II Preparation of a house wiring circuit on wooden board using fuse, switches, socket, holder, ceiling rose etc. in PVC conduit wiring system.
- Job III Make conduit connection to control one lamp from two different places with two different switches according to a given route diagram (staircase wiring)

# SHEET METAL WORK

- Sheet metal work is working on metal sheets of 16 to 30 gauge, with hand tools and simple machines in order to convert the sheets into different forms.

# **CURRICULUM FOR SHEET METAL WORK**

- Introduction to sheet metal shop, use of hand tools and accessories e.g. different types of hammers, hard and soft mallet, sheet and wire gauge, necessary allowance required during job fabrication, selection of material and specifications.
- Introduction and demonstration of hand tools used in sheet metal shop.
- Introduction and demonstration of various machines and equipment used in sheet metal shop e.g. shearing machine, bar folder, burring machine, power press, sheet bending machine.
- Introduction and demonstration of various raw materials used in sheet metal shop e.g. M.S. sheet, galvanized-iron plain sheet, galvanised corrugated sheet, aluminium sheets etc.
- Job I Shearing practice on a sheet using hand shears.
- Practice on making single riveted lap joint/double riveted lap Joint.
- Students have to practice Rectangular tray, Conical/Cylindrical containers, Funnels etc.

# WELDING PRACTISE

Welding is the process of joining similar metals by the application of heat, with or without application of pressure or filler metal, in such a way that the joint is equivalent in composition and characteristics of the metal joined,

## 3.2 ELECTRIC ARC WELDING

Arc welding is the welding process, in which heat is generated by an electric arc struck between an electrode and the work piece. Electric arc is luminous electrical discharge between two electrodes through ionized gas.

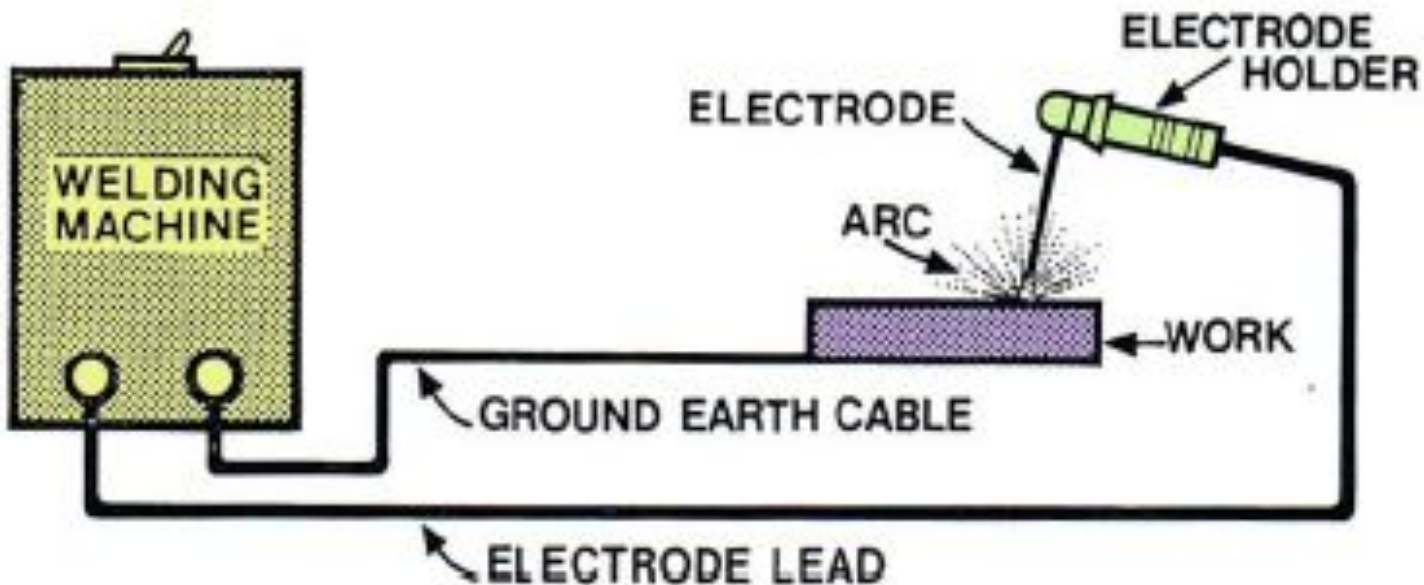

Figure 3.1: Arc welding set up.

# **CURRICULUM FOR WELDING**

- Introduction to welding and its importance in engineering practice; types of welding; common materials that can be welded, introduction to welding equipment e.g. a.c. welding set, d.c. rectifier, electrode holder, electrodes and their specifications, welding screens and other welding related equipment, accessories and gloves.
- Safety precautions during welding. Hazards of welding and its remedies.
- Electric arc welding, (a.c. and d.c.) precautions while using electric arc welding, Practice in setting current and voltage for striking proper arc. Earthing of welding machine.
- Job I Practice of striking arc bending and tacking while using electric arc welding set.
- Job II Welding practice on electric arc welding for making uniform and straight weld beads
- Various types of joints and end preparation.
- Job III Preparation of butt joint by electric arc welding.
- Job IV Preparation of lap joint by electric arc welding.
- Job V Preparation of corner joint by using electric arc welding.
- Job VI Preparation of Tee joint by electric arc welding.

# WELDING JOINTS AND WELD

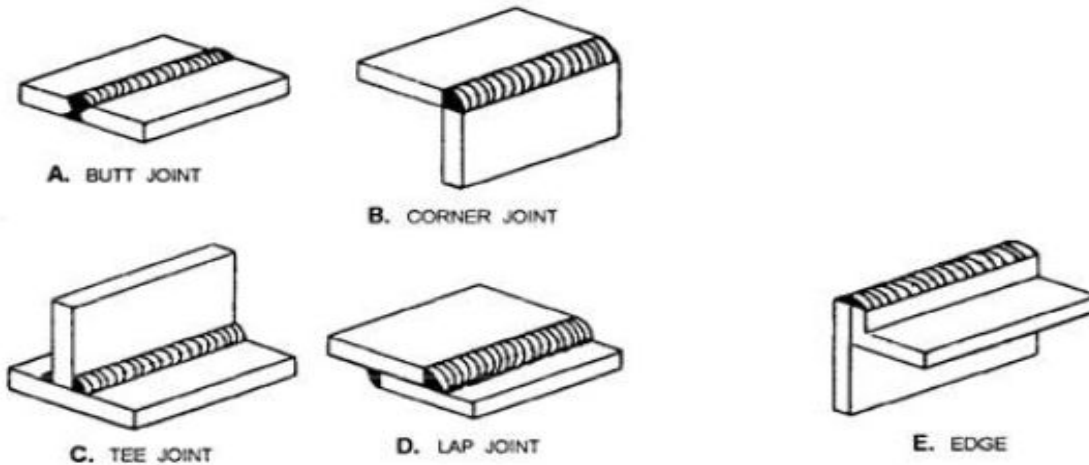

Figure 3.10: Types of welding joints.

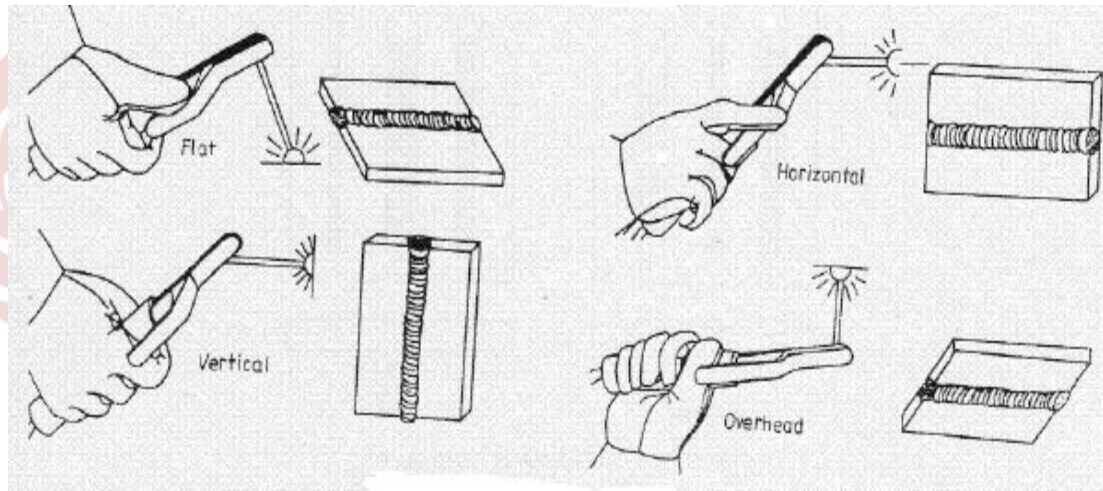

Figure 3.11: Welding positions



# SAFE PRACTICES IN WELDING

Always weld in a well ventilated place. Fumes given off from welding are unpleasant and in some cases may be injurious, particularly from galvanized or zinc coated parts.

1. Do not weld around combustible or inflammable materials, where sparks may cause a fire.
2. Never weld containers, which have been used for storing gasoline, oil or similar materials, without first having them thoroughly cleaned.
3. Check the welding machine to make sure that it is properly grounded and that all leads properly insulated.
4. Never look at the arc with the naked eye. The arc can burn your eyes severely. Always use a face shield while welding.
5. Prevent welding cables from coming in contact with hot metal, water, oil, or grease. Avoid dragging the cables around sharp corners.
6. Ensure proper insulation of the cables and check for openings.
7. Always wear the safety hand gloves, apron and leather shoes.
8. Always turn off the machine when leaving the work.
9. Apply eye drops after welding is over for the day, to relieve the strain on the eyes.
10. While welding, stand on dry footing and keep the body insulated from the electrode, any other parts of the electrode holder and the work.

# WORKSHOP SAFETY PRECAUTIONS

- Wear tight clothes. Loose clothing or long hair will bring danger
- Wear covered footwear. Never use sandals or chappels.
- Never use file, screwdrivers without handle.
- Do not use hammer without wedge.
- Never operate a machine unless otherwise you thoroughly its mechanism.
- Wear goggles while chipping, welding or grinding.
- Always wear safety hand gloves, apron or dungaree and leather shoes in the Workshop.
- Never touch overhead lines unless you are sure that it is properly earthed and dead.
- Do not throw water on the equipment. It will be harmful since water is a good conductor of electricity.